

# E330 Series

## Intel Apollo Lake SoC Modular Fanless Box PC



### Features

- Intel® Apollo Lake Series SoC
- Dual independent displays with HDMI and DP
- 3 x Gigabit LAN(2 x Intel i210/i211)
- 4 x Digital IO
- 1 x M.2 storage device
- Wide temperature operation:-20°C~60°C
- Fanless slim system
- Wall mounting design

### Specifications

		E330 Series
Processor System	CPU	Intel Apollo Lake N3350/N4200/J3355/J3455/J4205 series SoC
	Lithography	14nm
	L2 Cache	2 MB
	BIOS	AMI 8Mb UEFI BIOS
Memory	Technology	DDR3L 1600MHz
	Capacity	2GB (up to 8GB)
	Memory Chip	Memory chips Onboard
Display	Chipset	Intel® HD Graphics 505
	Graphics Engine	4K Codec Decode & Encode for H.264, MPEG2, MVC, VC-1, WMV9, H.265 / HEVC, VP9
	DP	Max. 4096 x 2160 @ 60Hz
	HDMI	Max. 3840 x 2160 @ 30Hz
Audio	Dual Display	Yes, HDMI + DP
	Controller	Realtek ALC662, High Definition Audio. Line-out, Mic-in
Ethernet	LAN1	RTL8111H GbE
	LAN2/LAN3	Intel i210 GbE
I/O Interface	USB Interface	2 x USB3.0, 2 x USB2.0
	Serial Ports	2 x RS232, 2 x RS485
	DIO	4 x DI(Opto-couplers isolation)
		4 x DO(Opto-couplers isolation)
Storage	eMMC	8GB, up to 256GB
	M.2	1 x 2242 SSD
	TF-Card	1 x TF
Power Supply	DC Input	24V DC
OS	Microsoft Windows	Windows 10 64Bit
Physical Characteristics	Construction	Aluminium Alloy
	Mounting	Wall Mounting
	Dimensions	120 x 100 x 51mm (LxWxH)
	Weight	0.65 Kg
Environment	Operating Temperature	-20°C~60°C, airflow 0.7m/s
	Storage Temperature	-40°C~80°C
	Relative Humidity	95% @ 40°C ( Non-Condensing)
	Vibration During Operation	With SSD : 3Grms, IEC 60068-2-64, random vibration, 5~500Hz, 1hr/axis
	Shock During Operation	With SSD : 30 G, IEC 60068-2-27, half sine, 11m duration
	ESD	Contact +/-4 KV Air +/-8 KV
	EMC	CE/FCC Class B

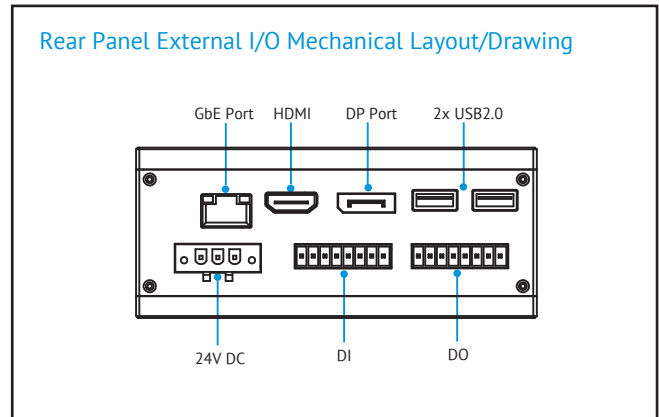
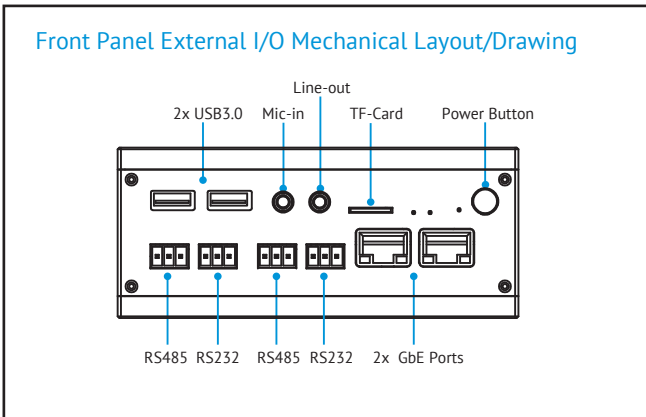
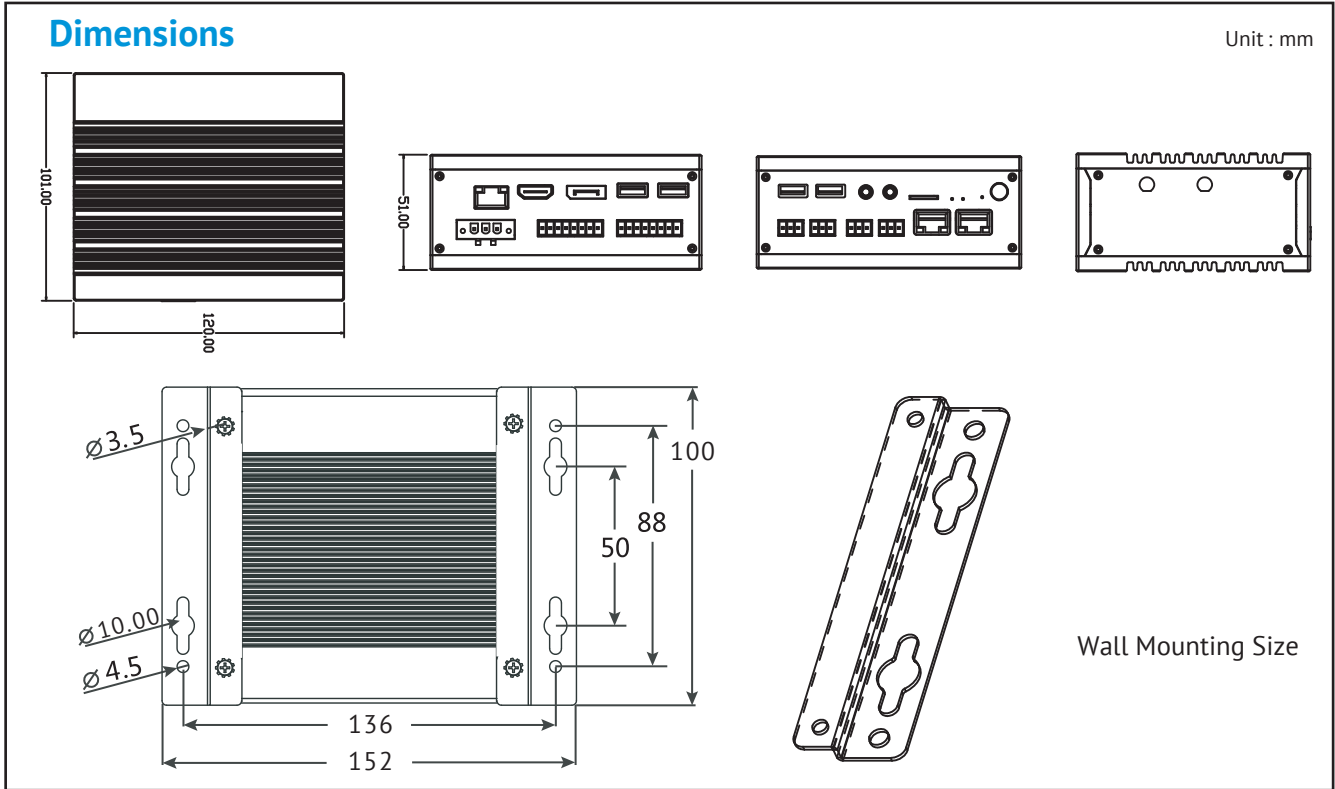

## Ordering Information

P/N	CPU	Memory	GbE	USB2 .0	USB3 .0	RS -232	RS -485	Audio	DIO	eMMC	TF	M.2 SSD	Power Input
E330-2260	Intel Pentium J3455 2.3 GHz SoC	4GB	3	2	2	2	2	Line - out Mic-in	4xDIO	-	1	128GB	24V 3PIN Phoenix
E330-3260	Intel Pentium N4200 2.5 GHz SoC	4GB	3	2	2	2	2	Line - out Mic-in	4xDIO	-	1	128GB	24V 3PIN Phoenix
E330-5260	Intel Pentium J4205 2.6 GHz SoC	4GB	3	2	2	2	2	Line - out Mic-in	4xDIO	-	1	128GB	24V 3PIN Phoenix

## Packing List

P/N	Description
	1 x E330 Unit
	1 x 3PIN Phoenix

## Optional Item for Default SKU

P/N	Description
	Wall mounting kits
	AC-DC Adapter DC24V with 3PIN Phoenix